

Precision index drives for rotary motions

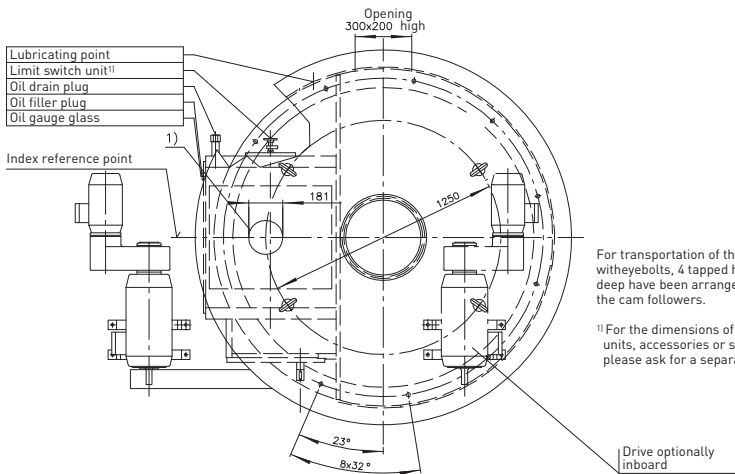
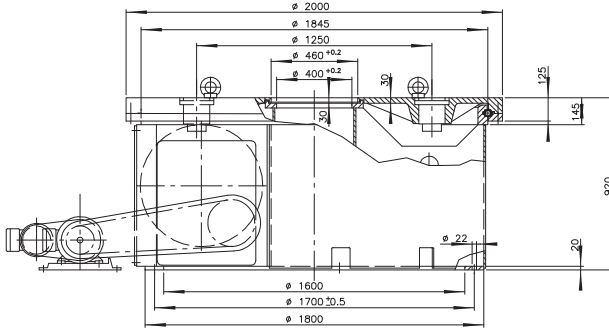

For transportation of the turntable with eyebolts, 4 tapped holes M30x45 deep have been arranged in the area of the cam followers.

¹⁾ For the dimensions of limit switch units, accessories or special design, please ask for a separate drawing.

²⁾ Location of the cam followers at the index reference point

[Free areas must be provided accordingly in the tool plate]

2/4 Indexing steps
8 cam followers

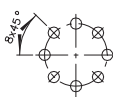

3/9 Indexing steps
9 cam followers

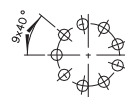

5/10 Indexing steps
10 cam followers

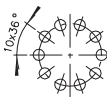

6/12 Indexing steps
12 cam followers

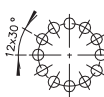

Technical data

Static bearing capacity of table plate bearing
(theoretic factors of the bearing manufacturer)

$C_{OA} = 3956000 \text{ N}$

$C_{OR} = 1861000 \text{ N}$

$C_{OM} = 1675000 \text{ Nm}$

Permissible resulting tangential moment, due to process related forces incurred while the table plate is at standstill: $M_t = 34650 \text{ Nm}$

Order example:

ED2000 2 7,0 400 V - 50 Hz

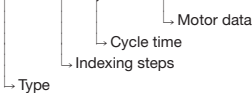

Indexing steps

Standard indexing steps: 2,3,4,5,6,8,9,10,12 further indexing steps on request

Tool plate

Mounting of tool plate see drwg.

Accuracy

order: ± 33 angular seconds

Total weight

High-precision performance upon request approx. 3500 kg (depending on size of motor)

Motor

C-flange motor to requirements

Remark

This type range permits the construction of special models with different technical data. In order to prepare a detailed offer, we would need exact technical information.